

APPROVAL SHEET

Customer Name : _____
 Customer P/N : _____
 Frequency : 12.000000 MHz
 Aker Approved P/N : SMAF-012000-3-D4-01
 Aker MPN : SMAF-012000-3-D4-01
 Rev. : 1
 ISSUE DATE : Feb.9.2023

| APPROVED | CHECKED | PREPARED |
|----------------------|---------|--------------|
| <i>Leaf</i> | | <i>Jimmy</i> |
| APPROVED BY CUSTOMER | | |
| | | |

AKER TECHNOLOGY CO., LTD.

ADDRESS : NO 11-3, Jianguo Rd., Tanzi Dist., Taichung City 427, Taiwan.

TEL : 886-4-25335978 FAX : 886-4-25336011

Web: www.aker.com.tw

MSL:Level 1

RoHS Compliant

IATF 16949 Certified

AEC-Q200 Qualified



| | | | |
|---------------------|---|---------------------|----------------|
| Aker Approved P/N : | | SMAF-012000-3-D4-01 | |
| APPROVED | : | Xtal | SHEET : 2 of 9 |
| PREPARED | : | Jimmy | REV . : 1 |
| | | | Confidential |

SMD CRYSTAL OSCILLATOR

1. ELECTRICAL CHARACTERISTICS

■ Standard atmospheric conditions

Unless otherwise specified , the standard range of atmospheric conditions for making measurement and tests are as follow :

Ambient temperature : 25±5 °C

Relative humidity : 40%~70%

If there is any doubt about the results , measurement shall be made within the following limits :

Ambient temperature : 25±3 °C

Relative humidity : 40%~70%

■ AKER Model : SMAF-321

■ Cutting Mode : AT CUT

| Parameters | Symbol | Electrical Spec | | | | Notes |
|---------------------------|------------------|--------------------|------|--------------------|--------|------------------------------|
| | | Min. | Typ. | Max. | Units. | |
| Nominal Frequency | | 12.000000 | | | MHz | |
| Frequency Stability | | ±50 | | | ppm | |
| Supply Voltage | V _{CC} | 1.6 | ~ | 2.2 | V | |
| Output Load CMOS | CL | | | 15 | pF | |
| Aging | | ±3 | | | ppm | First Year |
| Enable Control | | Yes | | | | Pad 1 |
| Operating Temperature | | -40 | 25 | 85 | °C | |
| Storage Temperature Range | | -55 | ~ | 150 | °C | |
| Output Voltage High | V _{OH} | 90%V _{DD} | | | V | |
| Output Voltage Low | V _{OL} | | | 10%V _{DD} | V | |
| Input Current | I _{CC} | | | 6 | mA | |
| Standby Current | I _{ST} | | | 10 | μA | |
| Rise Time | T _r | | | 7 | ns | 10%~90%V _{DD} Level |
| Fall Time | T _f | | | 7 | ns | 90%~10%V _{DD} Level |
| Symmetry (Duty ratio) | TH/T | 45 | ~ | 55 | % | |
| Start-up Time | T _{OSC} | | | 10 | ms | |
| Enable Voltage High | V _{HI} | 70%V _{DD} | | | V | |
| Disable Voltage Low | V _{LO} | | | 30%V _{DD} | V | |
| Output Enable Delay Time | T _{ON} | | | 10 | ms | |
| Output Disable Delay Time | T _{OFF} | | | 200 | ns | |
| Phase Jitter RMS | | | | 1 | ps | 12KHz~5MHz |

Please kindly be noted that AKER DO NOT guarantee parts quality which involves human security application.

2 . C - MOS LOAD OUTPUT WAVEFORM

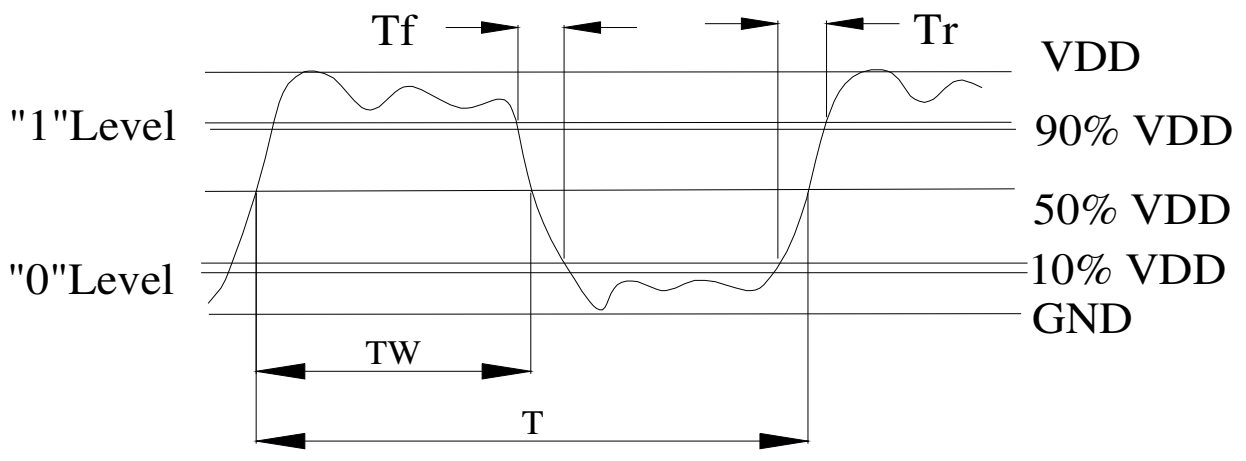

3 . C - MOS LOAD TEST CIRCUIT

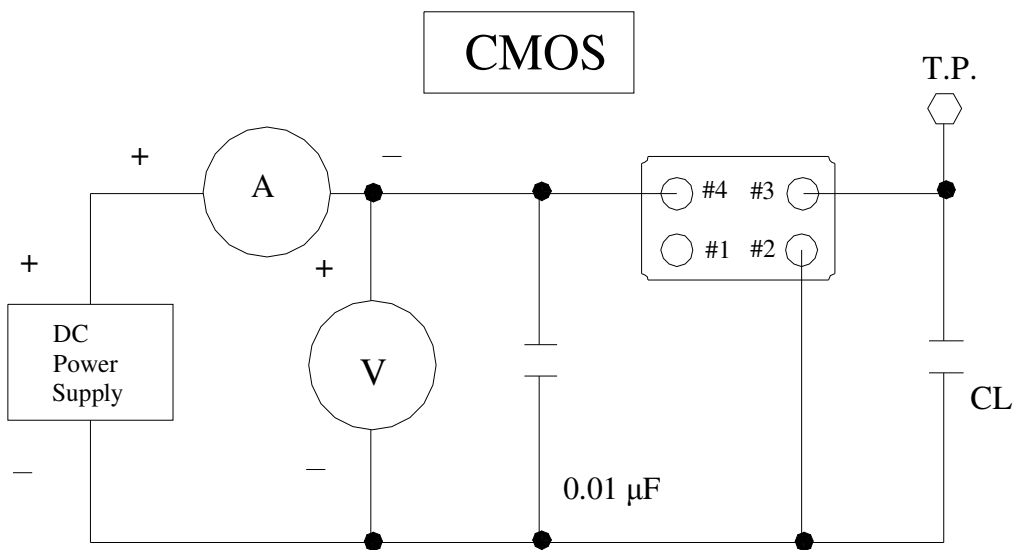

***Because SMA series has no by pass capacitor.
So,we recommend our customer to use capacitor 0.01 μ F
in join Vcc and GND.

4. MARKING :

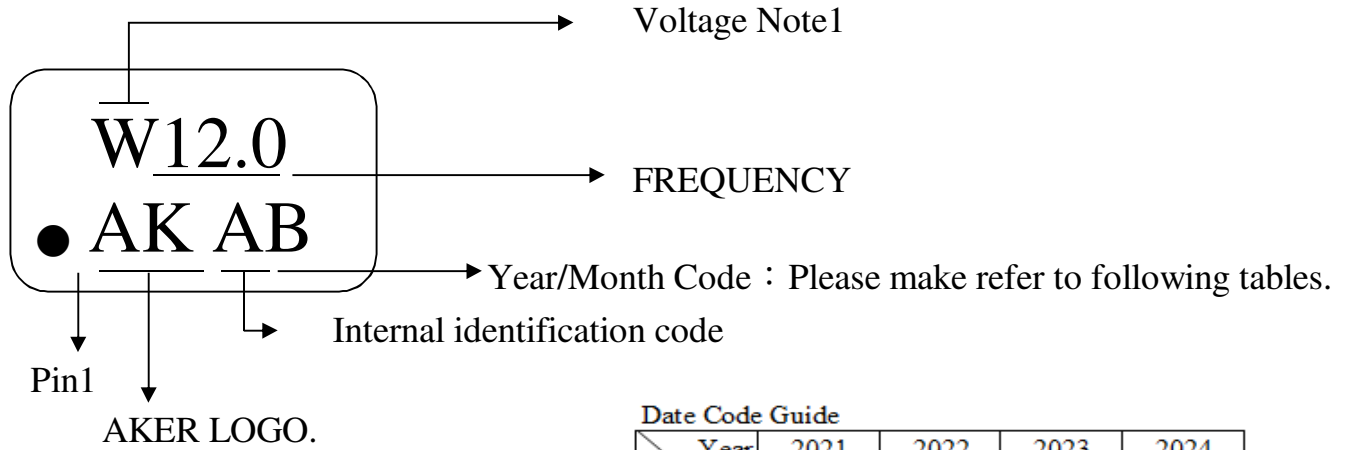

NOTE1:

| | |
|---|---------------------|
| T | 5.0V TTL |
| C | 4.5~5.0V CMOS |
| L | 2.97~3.63V TTL&CMOS |
| R | 2.8~3.0V CMOS |
| S | 2.25~2.75V CMOS |
| Y | 1.5~2.0V CMOS |
| Z | 0.8~1.4V CMOS |
| W | Voltage Range CMOS |

Date Code Guide

| Year | 2021 | 2022 | 2023 | 2024 |
|-------|--------|--------|--------|--------|
| | 2025 | 2026 | 2027 | 2028 |
| Month | (4N+1) | (4N+2) | (4N+3) | (4N+0) |
| JAN | a | n | A | N |
| FEB | b | p | B | P |
| Mar | c | q | C | Q |
| Apr | d | r | D | R |
| May | e | s | E | S |
| Jun | f | t | F | T |
| Jul | g | u | G | U |
| Aug | h | v | H | V |
| Sep | j | w | J | W |
| Oct | k | x | K | X |
| Nov | l | y | L | Y |
| Dec | m | z | M | Z |

A cycle every four years

5. DIMENSION :

(UNIT : mm)

Enable / Disable Function

| | |
|-------------|----------------|
| E/D (#1) | OUTPUT (#3) |
| HIGH (Open) | Operating |
| LOW | High impedance |

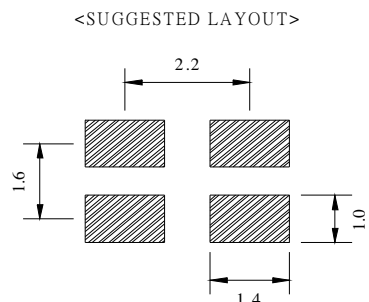
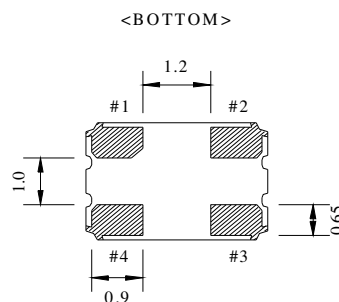
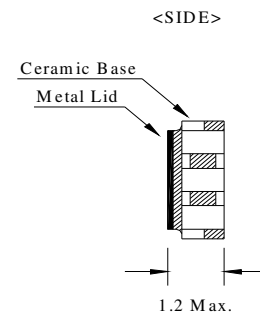
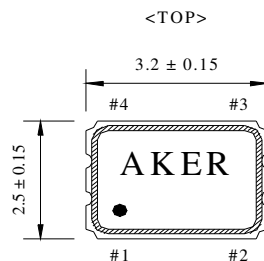

PIN FUNCTION

- #1 : Enable / Disable Control
- #2 : GND
- #3 : OUTPUT
- #4 : VDD

6 . STRUCTURE ILLUSTRATION

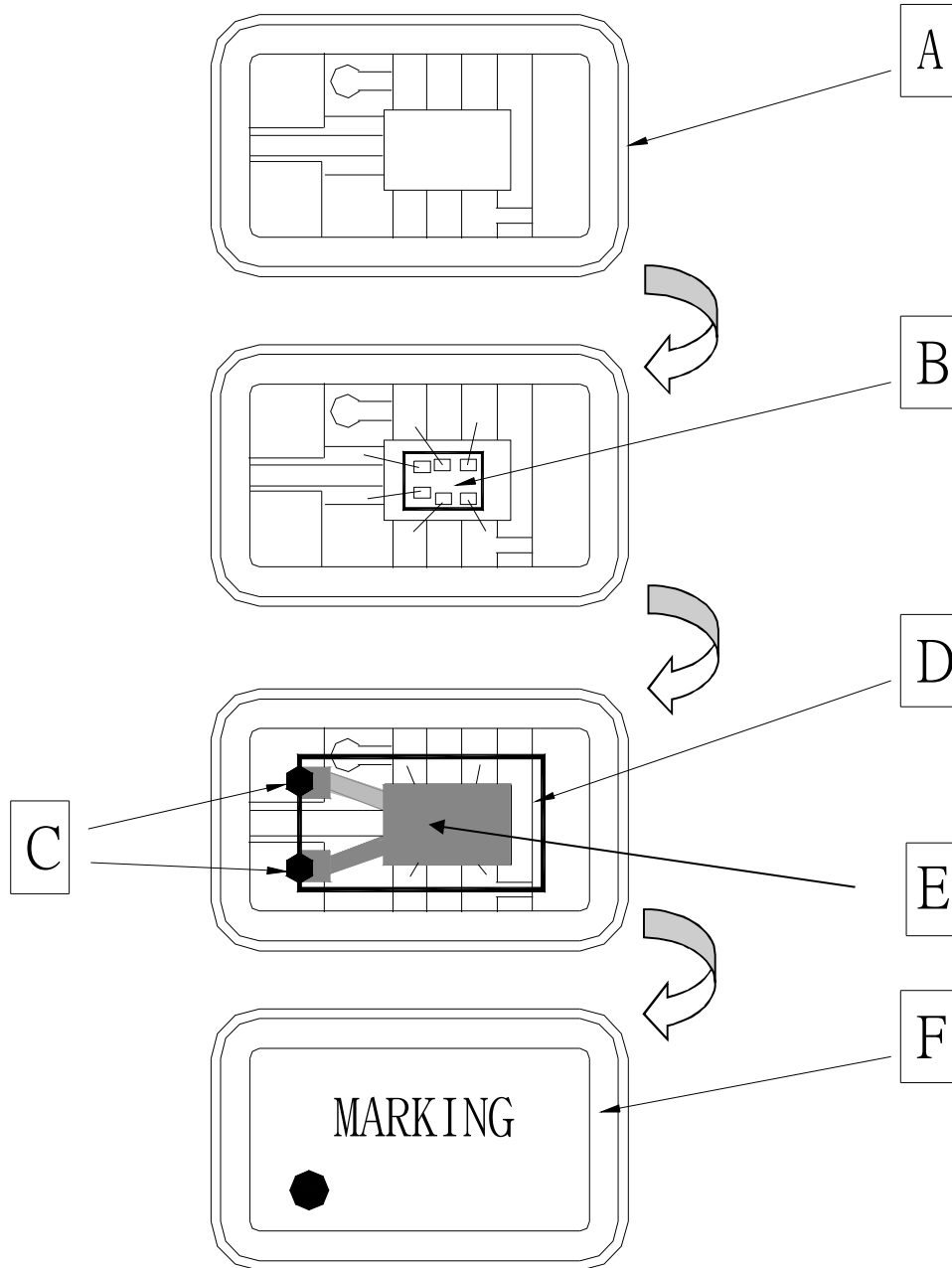

| COMPONENTS | | MATERIALS | COMPONENTS | | MATERIALS |
|------------|---------------------|--|------------|---------------|------------------|
| A | Base (Package) | Ceramic (Al ₂ O ₃)+Kovar (Fe/Co/Ni) | D | Crystal blank | SiO ₂ |
| B | IC chip | - | E | Electrode | Cr / Ag |
| C | Conductive adhesive | Ag / Silicon resin | F | Lid | Fe/Co/Ni |

7. PACKING :

TAPE SPECIFICATION

(Unit : mm)

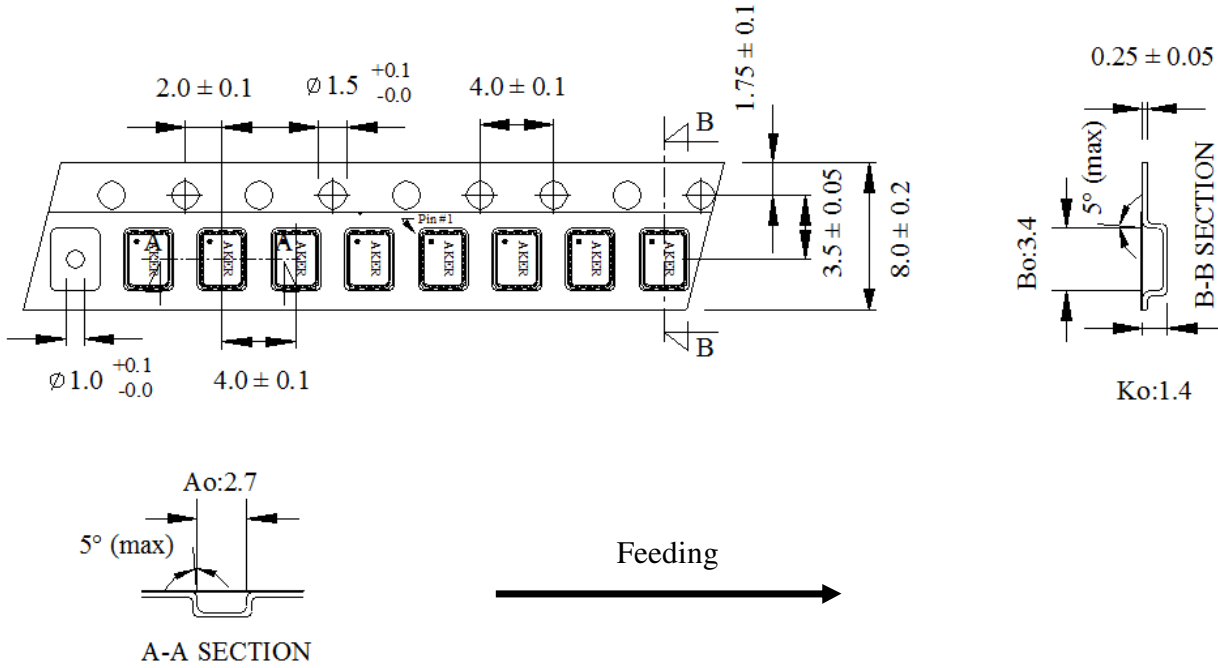

OUTLINE DIMENSION

(Unit : mm)

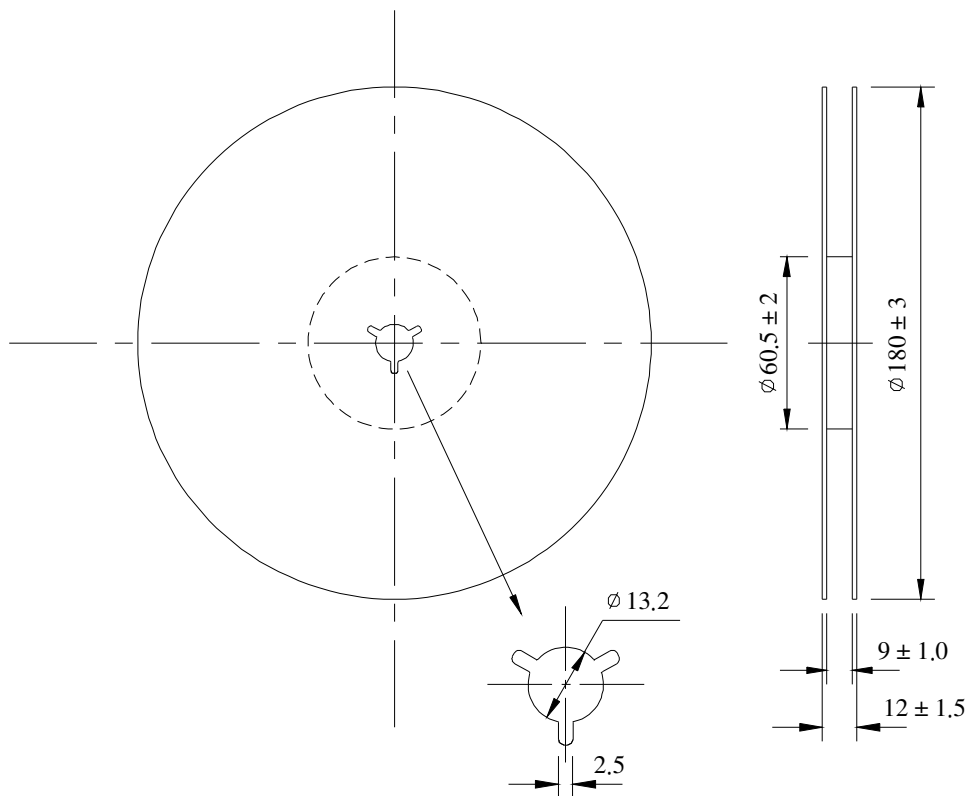

8. COVER TAPE ADHESION STRENGTH :

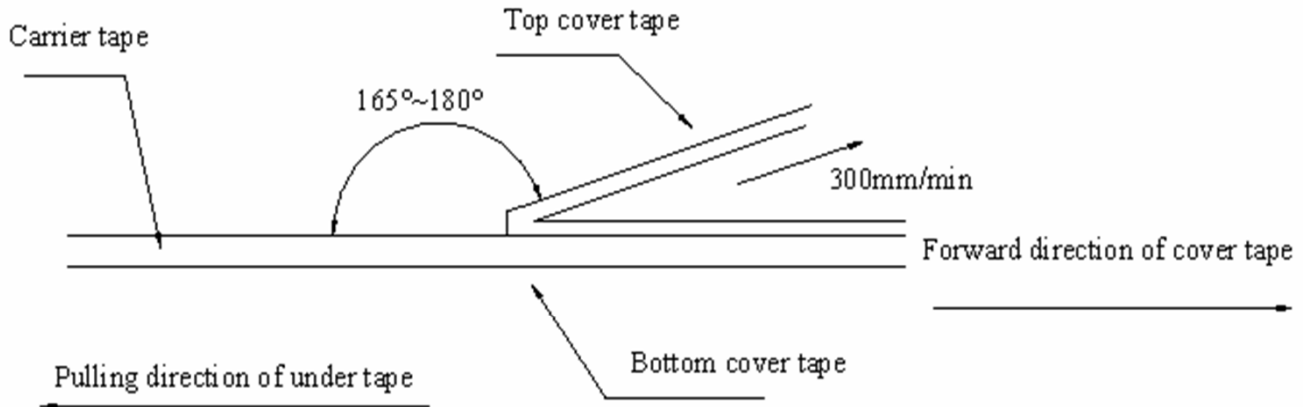

*** In the case, the cover tape is pulled off under the above conditions, the cover tape adhesion strength should be 10.2g~71.4g

Plastic tape: 10.2g~71.4g

(Cover tape adhesion strength)

9. SOLDERING REFLOW PROFILE

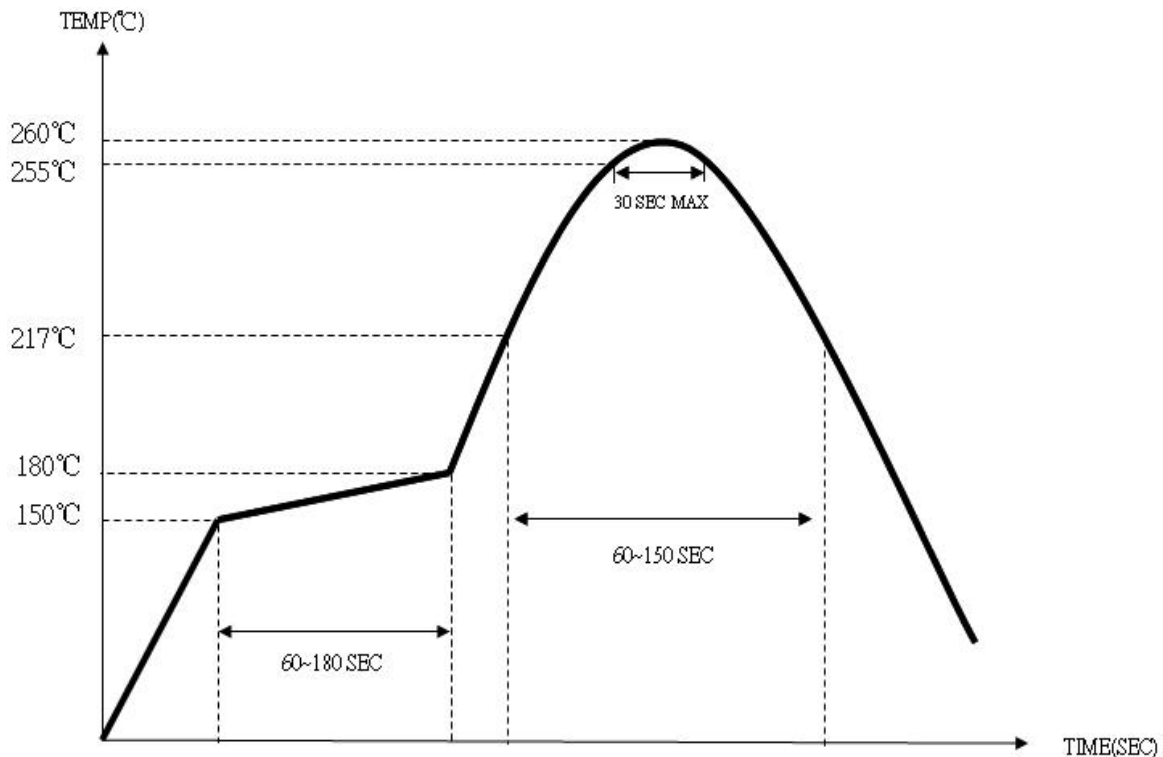

10. PACKING :

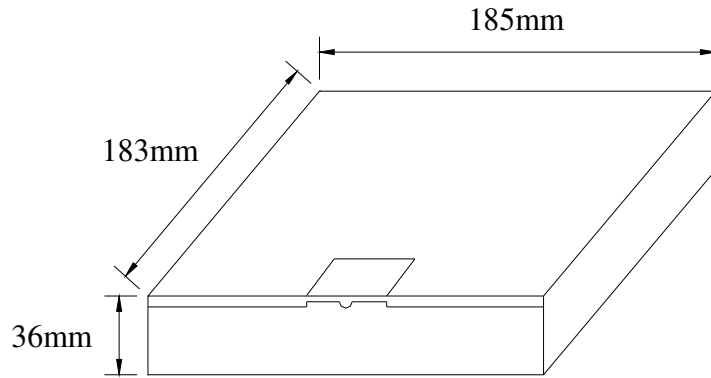

BOX = 3000 PCS / REEL(MAX)

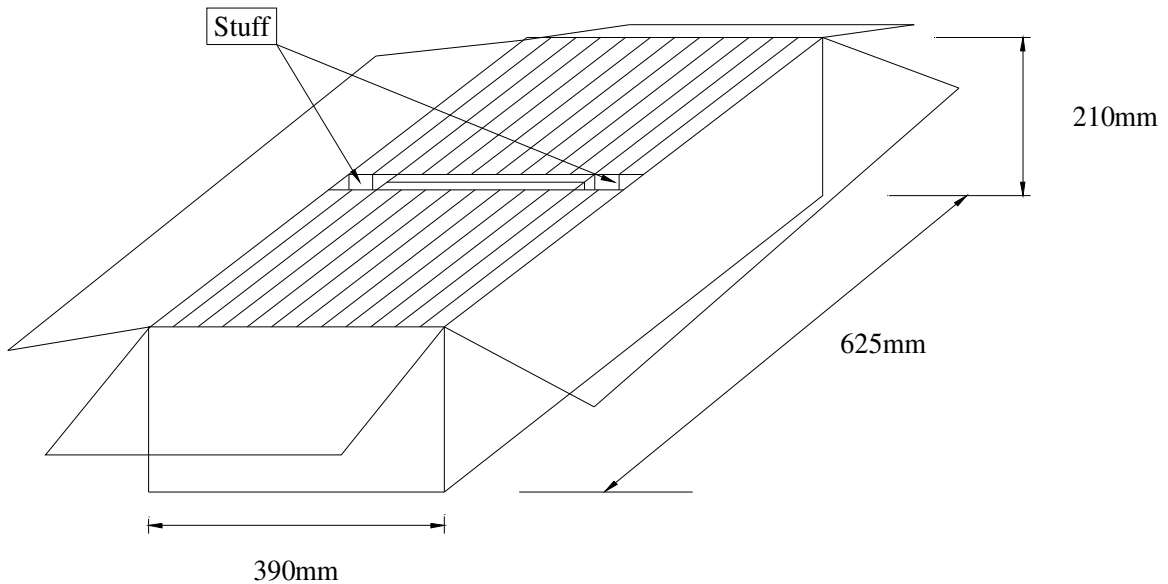
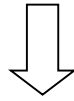

SMD product packs 32 BOX=The outside box packs (3000 PCS * 32 BOX = 96000 PCS)(MAX)



| | |
|---|---------------------|
| Aker Approved P/N : SMAF-012000-3-D4-01 | |
| APPROVED : | Xtal SHEET : 9 of 9 |
| PREPARED : | Jimmy REV . : 1 |
| Confidential | |

11 . MECHANICAL PERFORMANCE

| TEST ITEMS | TEST METHODS AND TEST CONDITION | PERFORMANCE |
|--|--|---|
| 11.1 Temperature Cycling | -55±3°C/30min maximum~+125±3°C/30min maximum , 1000cycles | To satisfy the electrical performance . |
| 11.2 Operational Life | 125°C ±3°C , 1000hrs±12hrs | |
| 11.3 Biased Humidity | 85°C±5°C&85%±5%R.H. , 1000±12hrs | |
| 11.4 Resistance To Soldering Heat Test | Reflow test 2 times. | |
| 11.5 High Temperature Exposure | 150°C ±3°C , 1000hrs±12hrs | |
| 11.6 Vibration Test | Freq.range: 10~2000Hz , Peak to peak amplitude:1.52mm Peak acceleration:5G (49m/s ²) , 3 direction(X, Y,Z) , 20min 12cycles each of 3 orientations. | |
| 11.7 Mechanical Shock | 100G , 6mS , 3 times for each direction(X, Y, Z) , 3 cycles | |
| 11.8 Physical Dimension | Verify physical dimensions to the applicable device detail specification. | |
| 11.9 Solderability | 260°C , Coated > 95% | |
| 11.10 Board Flex | PCB=100*40(mm) , Bending=2 mm (min) , Duration=60+5/-0 sec | |
| 11.11 External Visual | Inspect device construction and marking. | |
| 11.12 Terminal Strength | A force of 17.7N for 60 seconds. | |