

APPROVAL SHEET

Customer Name : _____
 Customer P/N : _____
 Frequency : 12.000000 MHz
 Aker Approved P/N : SMAN-012000-5-D4-00
 Aker MPN : SMAN-012000-5-D4-00
 Rev. : 1
 ISSUE DATE : Feb.10.2023

| APPROVED | CHECKED | PREPARED |
|----------------------|---------|-------------|
| <i>Tim</i> | | <i>Jing</i> |
| APPROVED BY CUSTOMER | | |
| | | |

AKER TECHNOLOGY CO., LTD.

ADDRESS : NO 11-3, Jianguo Rd., Tanzi Dist., Taichung City 427, Taiwan.

TEL : 886-4-25335978 FAX : 886-4-25336011

Web: www.aker.com.tw

MSL:Level 1

RoHS compliant



| | | | |
|---------------------|---------------------|-----------------|--|
| Aker Approved P/N : | SMAN-012000-5-D4-00 | | |
| APPROVED : | Tin | SHEET : 2 of 10 | |
| PREPARED : | JLING | REV . : 1 | |
| Confidential | | | |

SMD CRYSTAL OSCILLATOR

1. ELECTRICAL CHARACTERISTICS

■ Standard atmospheric conditions

Unless otherwise specified , the standard range of atmospheric conditions for making measurement and tests are as follow :

Ambient temperature : 25±5 °C

Relative humidity : 40%~70%

If there is any doubt about the results , measurement shall be made within the following limits :

Ambient temperature : 25±3 °C

Relative humidity : 40%~70%

■ AKER Model : SMAN-531

■ Cutting Mode : AT CUT

| Parameters | Symbol | Electrical Spec | | | | Notes |
|---------------------------|------------------|--------------------|------|--------------------|--------|------------------------------|
| | | Min. | Typ. | Max. | Units. | |
| Nominal Frequency | | 12.000000 | | | MHz | |
| Frequency Stability | | ±50 | | | ppm | |
| Supply Voltage | V _{CC} | 1.62 | ~ | 3.63 | V | |
| Output Load CMOS | CL | | | 15 | pF | |
| Aging | | ±3 | | | ppm | First Year |
| Enable Control | | Yes | | | | Pad 1 |
| Operating Temperature | | -40 | 25 | 85 | °C | |
| Storage Temperature Range | | -55 | ~ | 125 | °C | |
| Output Voltage High | VoH | 90%V _{DD} | | | V | |
| Output Voltage Low | VoL | | | 10%V _{DD} | V | |
| Input Current | I _{CC} | | | 7 | mA | |
| Standby Current | I _{ST} | | | 10 | μA | |
| Rise Time | Tr | | | 10 | ns | 10%~90%V _{DD} Level |
| Fall Time | Tf | | | 10 | ns | 90%~10%V _{DD} Level |
| Symmetry (Duty ratio) | TH/T | 45 | ~ | 55 | % | |
| Start-up Time | T _{osc} | | | 10 | ms | |
| Enable Voltage High | V _{hi} | 70%V _{DD} | | | V | |
| Disable Voltage Low | V _{lo} | | | 30%V _{DD} | V | |
| Output Enable Delay Time | T _{on} | | | 10 | ms | |
| Output Disable Delay Time | T _{off} | | | 200 | ns | |
| Phase Jitter RMS | | | | 1 | ps | 12KHz~5MHz |

Please kindly be noted that AKER DO NOT guarantee parts quality which involves human security application.

2. C - MOS LOAD OUTPUT WAVEFORM

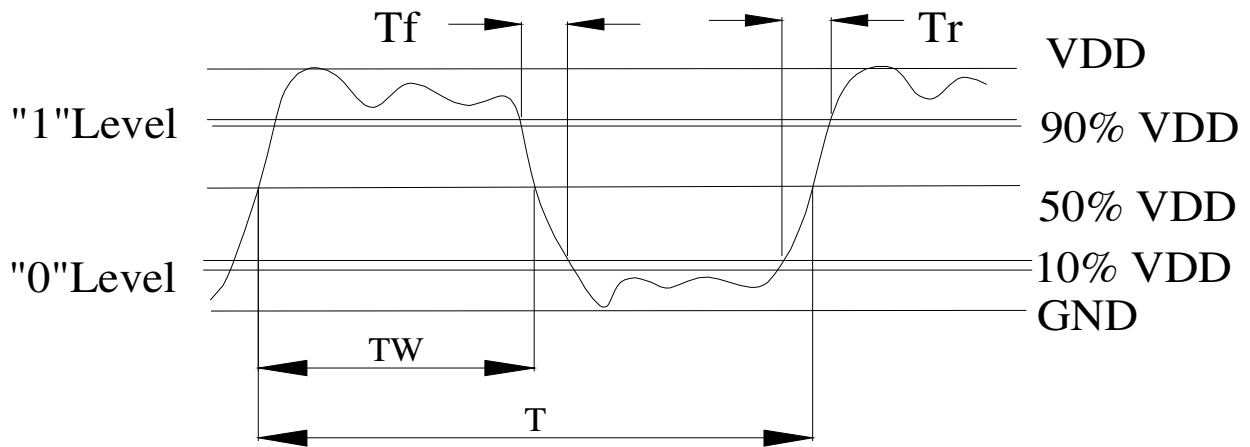

3. C - MOS LOAD TEST CIRCUIT

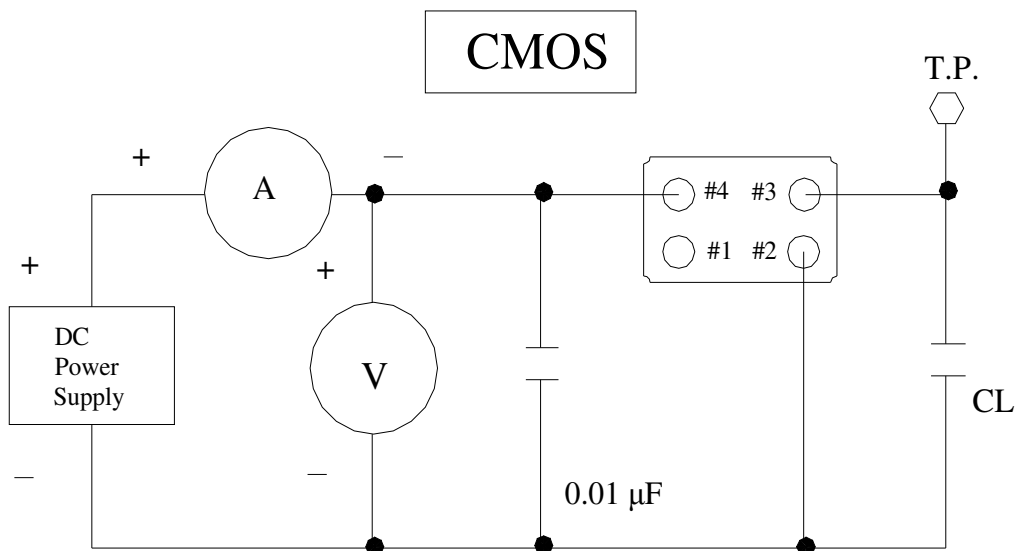

***Because SMA series has no by pass capacitor.
So, we recommend our customer to use capacitor 0.01 μF
in join Vcc and GND.

4. MARKING :

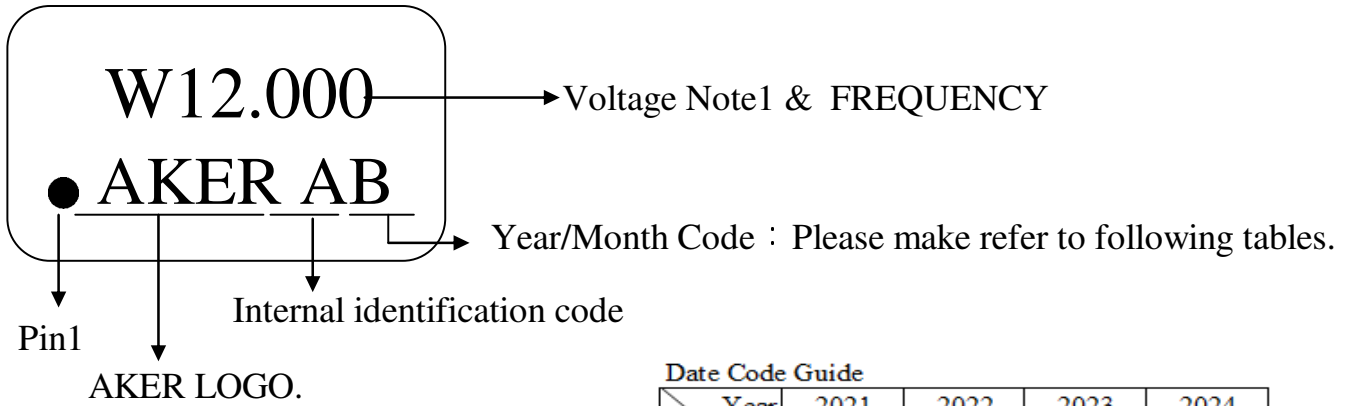

NOTE1:

| | |
|---|---------------------|
| T | 5.0V TTL |
| C | 4.5~5.0V CMOS |
| L | 2.97~3.63V TTL&CMOS |
| R | 2.8~3.0V CMOS |
| S | 2.25~2.75V CMOS |
| Y | 1.5~2.0V CMOS |
| Z | 0.8~1.4V CMOS |
| W | Voltage Range CMOS |

Date Code Guide

| Year | 2021 | 2022 | 2023 | 2024 |
|-------|--------|--------|--------|--------|
| | 2025 | 2026 | 2027 | 2028 |
| Month | (4N+1) | (4N+2) | (4N+3) | (4N+0) |
| JAN | a | n | A | N |
| FEB | b | p | B | P |
| Mar | c | q | C | Q |
| Apr | d | r | D | R |
| May | e | s | E | S |
| Jun | f | t | F | T |
| Jul | g | u | G | U |
| Aug | h | v | H | V |
| Sep | j | w | J | W |
| Oct | k | x | K | X |
| Nov | l | y | L | Y |
| Dec | m | z | M | Z |

A cycle every four years

5. DIMENSION :

(UNIT : mm)

Enable / Disable Function

| | |
|-------------|----------------|
| E/D (#1) | OUTPUT (#3) |
| HIGH (Open) | Operating |
| LOW | High impedance |

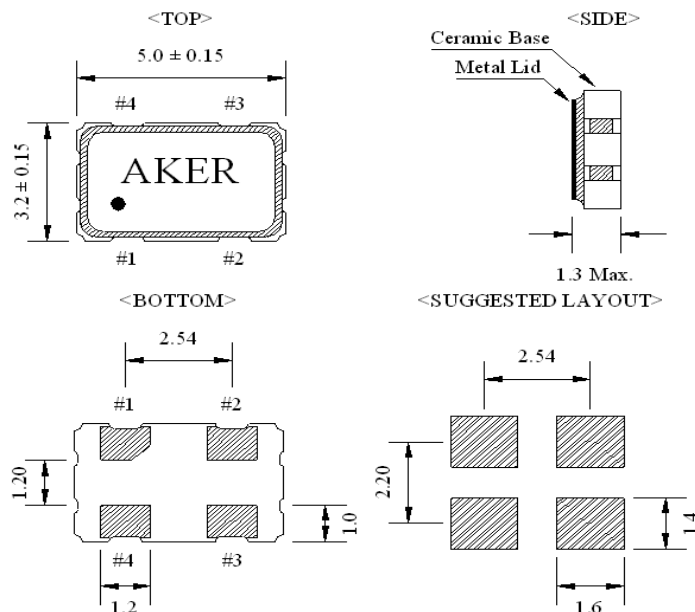

PIN FUNCTION

| |
|-------------------------------|
| #1 : Enable / Disable Control |
| #2 : GND |
| #3 : OUTPUT |
| #4 : VDD |

6 . STRUCTURE ILLUSTRATION

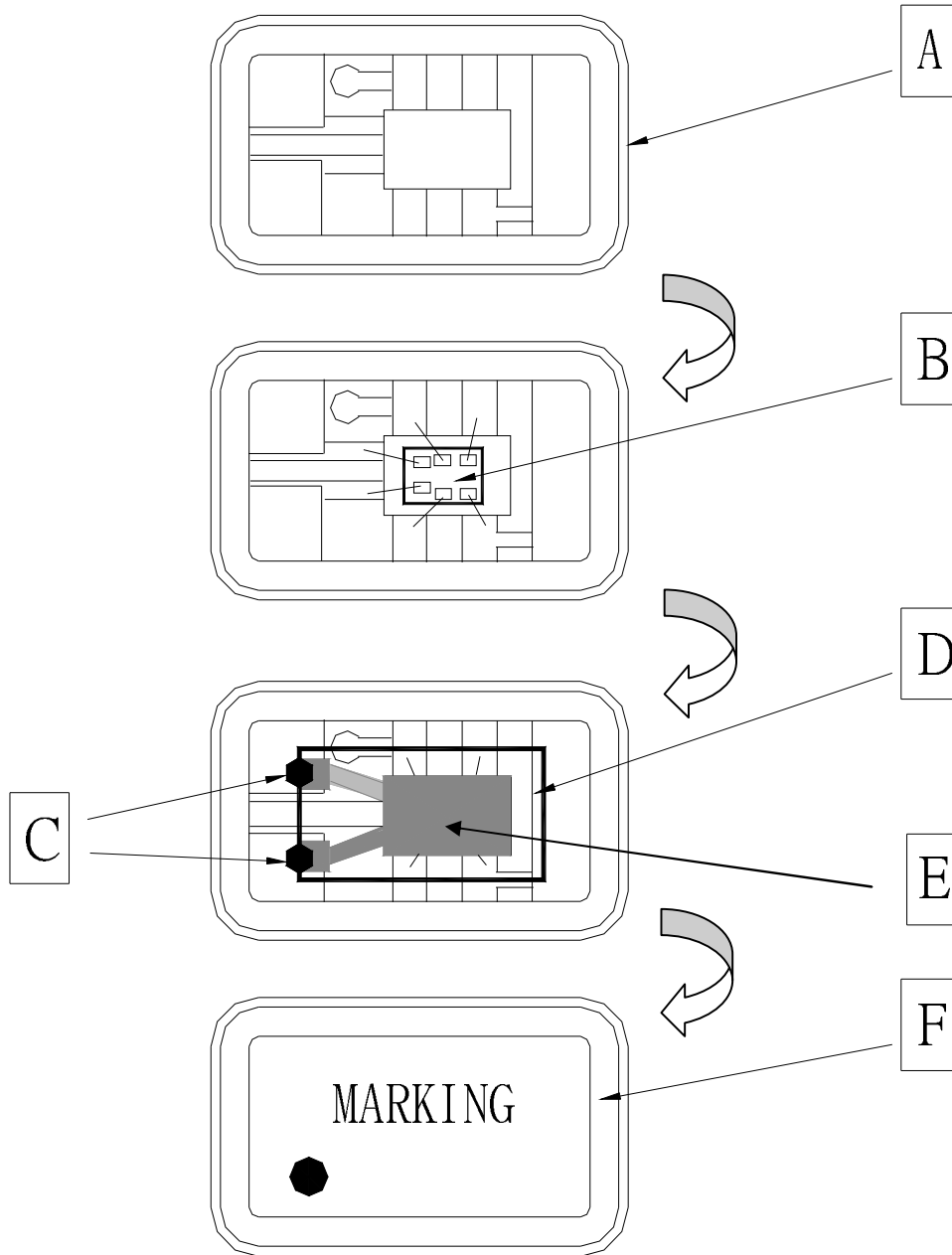

| COMPONENTS | | MATERIALS | | COMPONENTS | | MATERIALS | |
|------------|---------------------|--|--|------------|---------------|------------------|--|
| A | Base (Package) | Ceramic (Al ₂ O ₃)+Kovar (Fe/Co/Ni) | | D | Crystal blank | SiO ₂ | |
| B | IC chip | - | | E | Electrode | Cr / Ag | |
| C | Conductive adhesive | Ag / Silicon resin | | F | Lid | Fe/Co/Ni | |

7. PACKING :

TAPE SPECIFICATION

(Unit : mm)

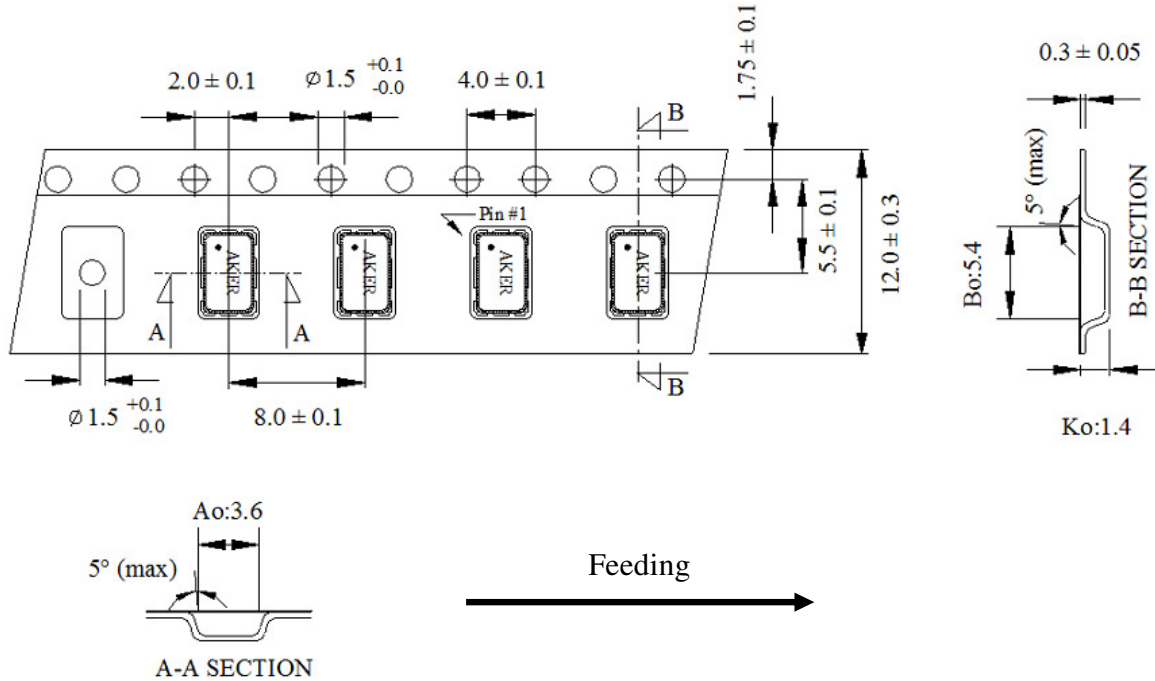

OUTLINE DIMENSION

(Unit : mm)

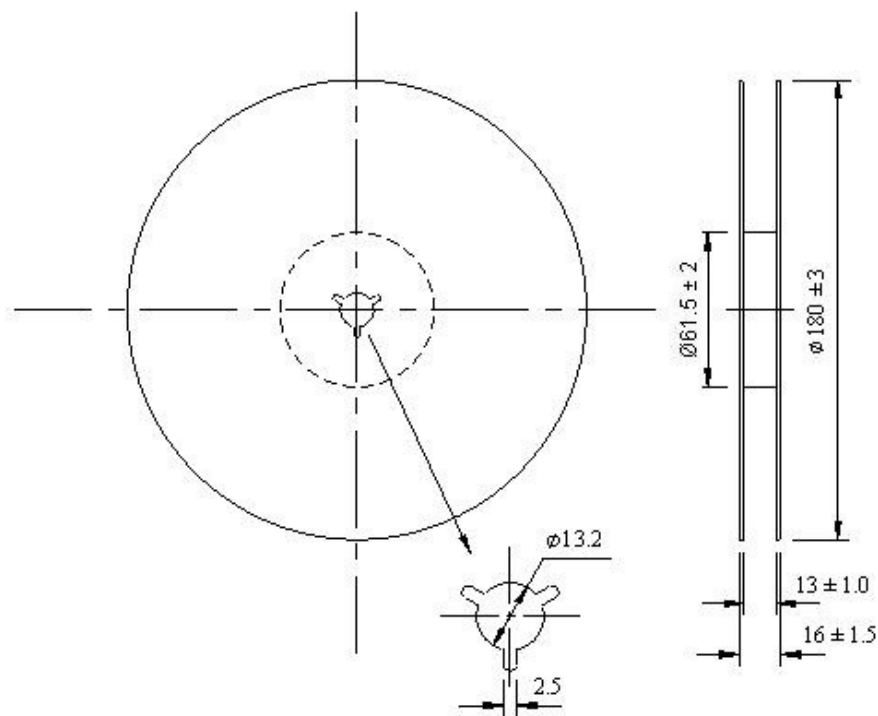

8. COVER TAPE ADHESION STRENGTH :

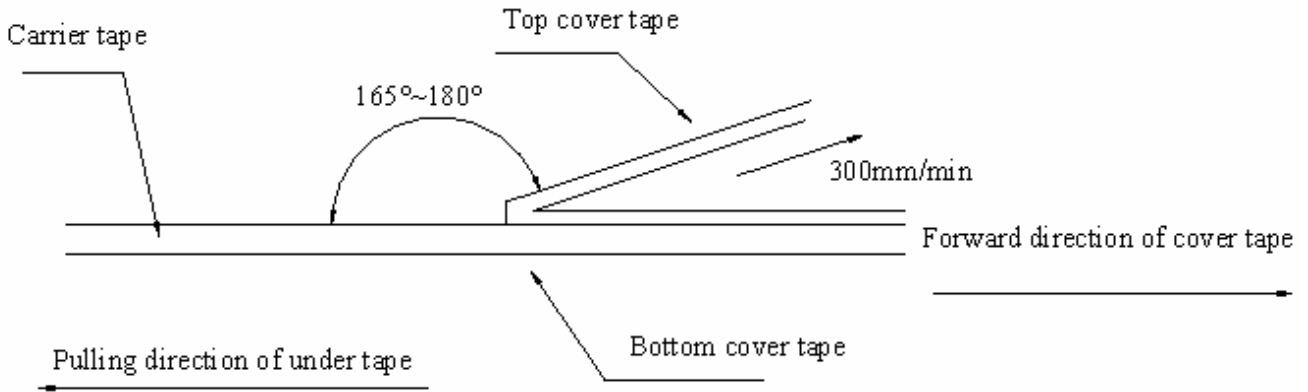

*** In the case, the cover tape is pulled off under the above conditions, the cover tape adhesion strength should be 10.2g~71.4g

Plastic tape: 10.2g~71.4g

(Cover tape adhesion strength)

9. SOLDERING REFLOW PROFILE

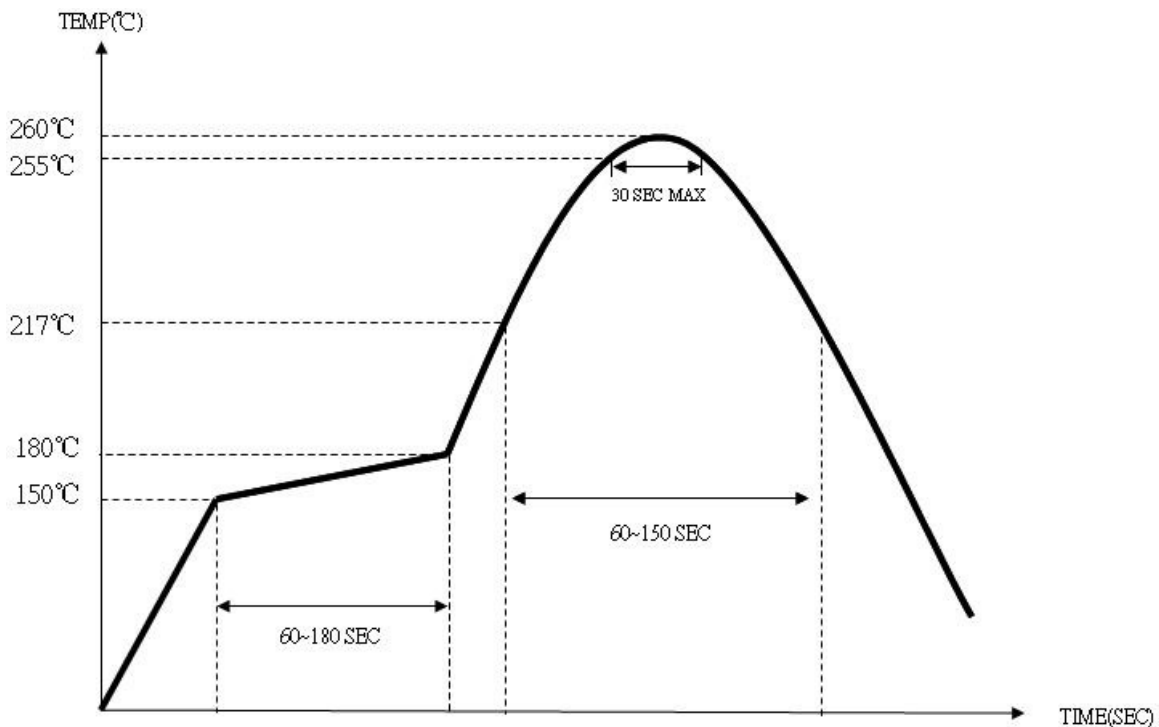

10. PACKING :

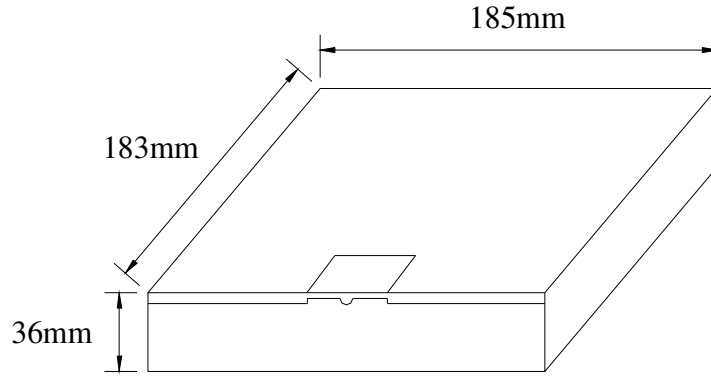

BOX = 1000 PCS / REEL

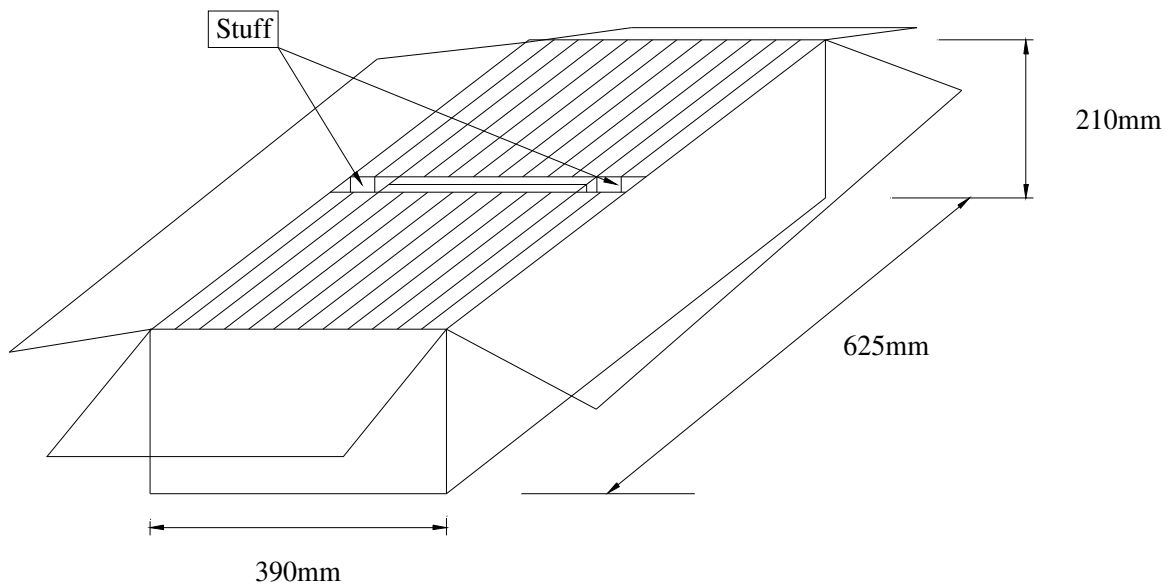

SMD product packs 32 BOX = The outside box packs (1000 PCS * 32 BOX = 32000 PCS)(MAX)



| | | | |
|---------------------|---|---------------------|-----------------|
| Aker Approved P/N : | | SMAN-012000-5-D4-00 | |
| APPROVED | : | Tin | SHEET : 9 of 10 |
| PREPARED | : | JLING | REV . : 1 |
| Confidential | | | |

11 . MECHANICAL PERFORMANCE

| TEST ITEMS | TEST METHODS AND TEST CONDITION | PERFORMANCE |
|---|--|---|
| 11.1 Drop Test | The specimen is measured for its frequency before the test. It is then dropped from a height of 75 cm or more as a free fall object onto a hard wooden plate of 30mm or more in thickness. (in accordance with JIS-C0044) | To satisfy the electrical performance . |
| 11.2 Vibration Test | The specimen is measured for its frequency before the test. Most them into X,Y and Z axes, respectively, for the vibration test. Vibration condition: Frequency range ; 20~2000HZ Peak to peak amplitude : 1.52 mm Peak acceleration : 20G Sweep time : 20 minute / axis Pendicular total test time : 4 hours (in accordance with MIL-STD-883F : 2007.3) | |
| 11.3 Resistance to Soldering Test | The specimen is measured for its frequency before the test. Place the specimen on the belt of the conveyance and let it pass through the reflow with the presetted temperature condition. After passing twice the reflow place,the specimen under the referee condition for ~2 hours and then measure its electrical performance. Temperature Condition of IR Simulation: The temperature range of the preheated section is setted at 150~180°C for 60~120 sec. For the next section the temperature range is setted at 217~260°C for 45~90 sec. and within this time range the specimen should be able to sustain at the peak temperature, 260+/-3°C , for 10 sec long. (in accordance with JESD22-B106-B) | |
| 11.4 Fine Leak Test | Place the specimen in a pressurized container and pressurize it with the detection gas (mixed gas consisting of 95% or more helium) for at least 2 hours. Complete the measurement of the concentration of helium within 30 min after taking it out from the pressurized container. (in accordance with MIL-STD-883F : 1014.11) | Less than $1.0 * 10^{-8}$ atm .c.c. / sec, Helium |
| The referee condition . Temperature 25 ± 2 °C Humidity 44 ~ 55 % Pressure 86 ~ 106 kPa (in accordance with MIL-STD-883E : 1014.9) | | |



| | | |
|---------------------|---------------------|------------------|
| Aker Approved P/N : | SMAN-012000-5-D4-00 | |
| APPROVED : | Tin | SHEET : 10 of 10 |
| PREPARED : | JLING | REV . : 1 |
| Confidential | | |

12 . CLIMATIC RESISTANCE

| TEST ITEMS | TEST METHODS AND TEST CONDITION | PERFORMANCE |
|--------------------------------------|---|---|
| 12.1 Low Temp Exposure Test | <p>The specimen is measured for its frequency before the test .</p> <p>Place the specimen in the chamber and kept it at the temperature of $-40 \pm 3^{\circ}\text{C}$ for 168 ± 6 hours .</p> <p>Take the specimen out of the chamber and measure itselectrical performance after leaving 1~2 hours under the referee condition. (in accordance with JIS-C0020)</p> | To satisfy the electrical performance . |
| 12.2 Aging Test | <p>The specimen is measured for its frequency before the test .</p> <p>Place the specimen in the testing chamber and keep it at the temperature of $+125 \pm 3^{\circ}\text{C}$ for 720 ± 48 hours. And then take the specimen out of the chamber and measure its electrical performance after leaving for 1 ~ 2 hours under the referee condition . (in accordance with JIS-C0021)</p> | |
| 12.3 High Temperature & High Humidty | <p>The specimen is measured for its frequency before the test .</p> <p>Place the specimen in the testing chamber and kept it at the temperature of $+85 \pm 5^{\circ}\text{C}$ and humidity of $85 \pm 5\%$ for 168 ± 6 hours.and then take the specimen out and measure its electrical performance after leaving for 1~2 hours under the referee condition. (in accordance with MIL-STD-883F : 1004.7)</p> | |
| 12.4 Temperature Cycle Test | <p>The specimen is measured for its frequency before the test .</p> <p>Subject the specimen to the 100 cycles of temperature ranges stated below .</p> <div style="text-align: center;"> <p>High temp . $+125 \pm 3^{\circ}\text{C}$ (15 ± 3 min).</p> <p>Low temp . $-55 \pm 3^{\circ}\text{C}$ (15 ± 3 min).</p> </div> <p>Measure its electrical performance after leaving it for 1 ~ 2 hours under the referee condition . (in accordance with MIL-STD-883F : 1010.8)</p> | |