



APPROVAL SHEET

Customer Name : _____
 Customer P/N : _____
 Frequency : 38.400000 MHz
 Aker Approved P/N: TXOF-038400-2-D4-01
 Aker MPN : TXOF-038400-2-D4-01
 Rev. : 1
 ISSUE DATE : Feb.13.2023

APPROVED	CHECKED	PREPARED
		
APPROVED BY CUSTOMER		

AKER TECHNOLOGY CO., LTD.

ADDRESS : NO 11-3, Jianguo Rd., Tanzi Dist., Taichung City 427, Taiwan.

TEL : 886-4-25335978 FAX : 886-4-25336011

Web: www.aker.com.tw

MSL:Level 1

RoHS compliant



Aker Approved P/N : TXOF-038400-2-D4-01	
APPROVED : Tin	SHEET : 2 of 8
PREPARED : Hitome	REV . : 1
Confidential	

SMD Temperature compensated crystal oscillator

1 . ELECTRICAL CHARACTERISTICS

■ Standard atmospheric conditions

Unless otherwise specified , the standard range of atmospheric conditions for making measurement and tests are as follow :

Ambient temperature : 25±5 °C

Relative humidity : 40%~70%

If there is any doubt about the results , measurement shall be made within the following limits :

Ambient temperature : 25±3 °C

Relative humidity : 40%~70%

■ AKER Model : TXOF-221

■ Cutting Mode : AT CUT

Parameters	Electrical Spec				Notes
	Min.	Typ.	Max.	Unit	
Nominal Frequency	38.400000			MHz	
Supply Voltage	3.135	3.3	3.465	V	
Frequency Tolerance	-1.5	~	1.5	ppm	After 2 times reflow soldering
Frequency Stability Over Temperature	-2.0	~	2.0	ppm	Between minimum and maximum frequency value over the specified temperature range.
Frequency Stability Over Supply Voltage	-0.2	~	0.2	ppm	
Frequency Stability Vs Load	-0.2	~	0.2	ppm	±10% Change
Operating Temperature Range	-30	~	85	°C	
Storage Temperature Range	-40	~	85	°C	
Current Consumption			2.0	mA	
Output Waveform	Clipped Sinewave				
Output Load	10KΩ // 10pF				
Output Voltage Level	0.8			Vp-p	
Phase Noise @100Hz Offset		-115		dBc/Hz	
Phase Noise @1Khz Offset		-131		dBc/Hz	
Phase Noise @10Khz Offset		-144		dBc/Hz	
Start Up Time			2.0	mSec	
Aging	-1.0	~	1.0	ppm	First Year

Please kindly be noted that AKER DO NOT guarantee parts quality which involves human security application.

2 . TCXO TESTING CIRCUIT

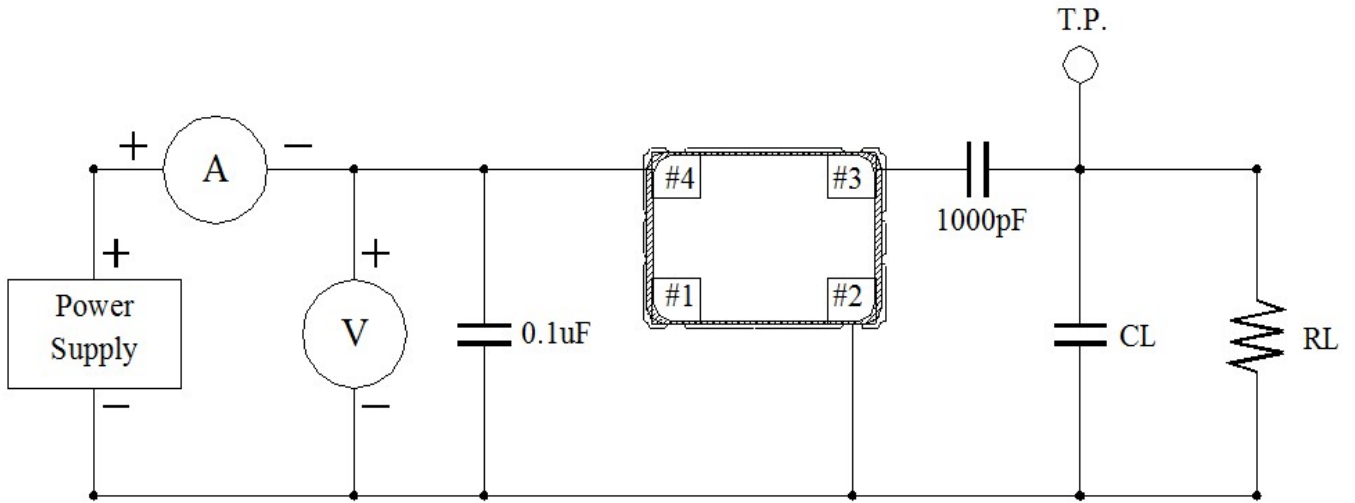

3 .MARKING :

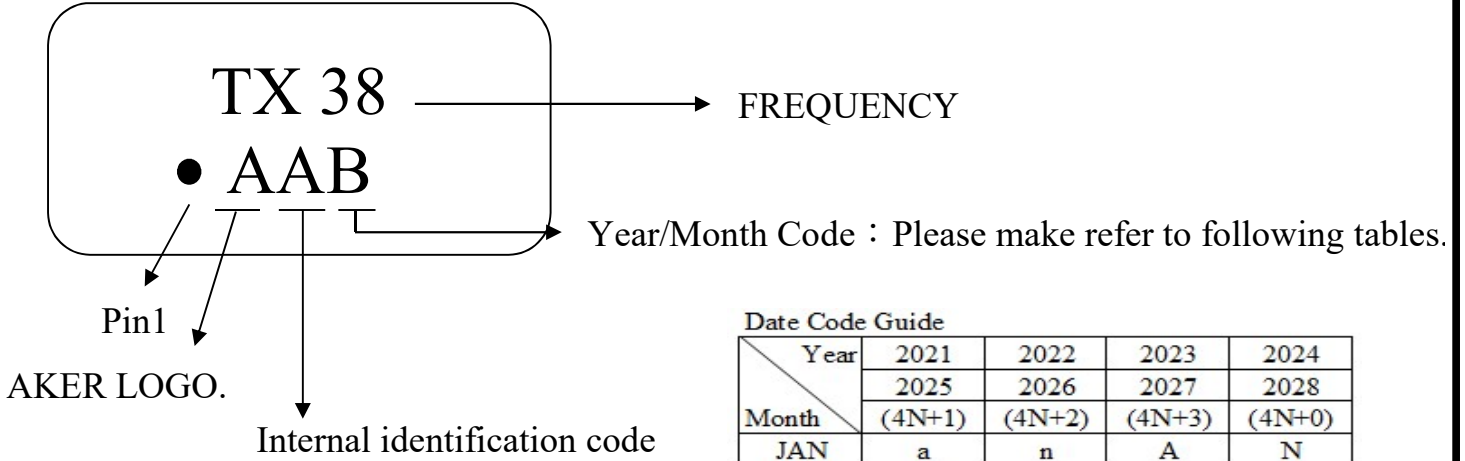

Date Code Guide

Year	2021	2022	2023	2024
	2025	2026	2027	2028
Month	(4N+1)	(4N+2)	(4N+3)	(4N+0)
JAN	a	n	A	N
FEB	b	p	B	P
Mar	c	q	C	Q
Apr	d	r	D	R
May	e	s	E	S
Jun	f	t	F	T
Jul	g	u	G	U
Aug	h	v	H	V
Sep	j	w	J	W
Oct	k	x	K	X
Nov	l	y	L	Y
Dec	m	z	M	Z

A cycle every four years

4 . DIMENSION :

(Unit : mm)

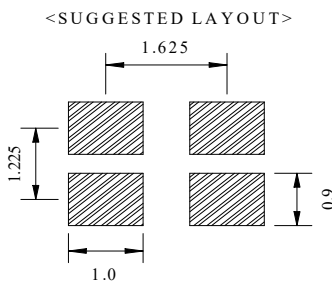
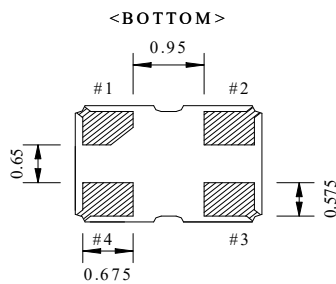
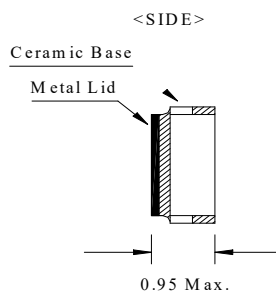
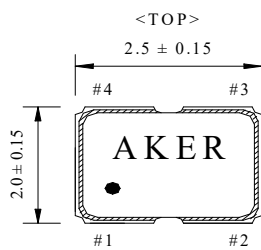

PIN No.	Connection
#1	NC / GND
#2	GND
#3	Output
#4	VDC

5. PACKING :

TAPE SPECIFICATION

(Unit : mm)

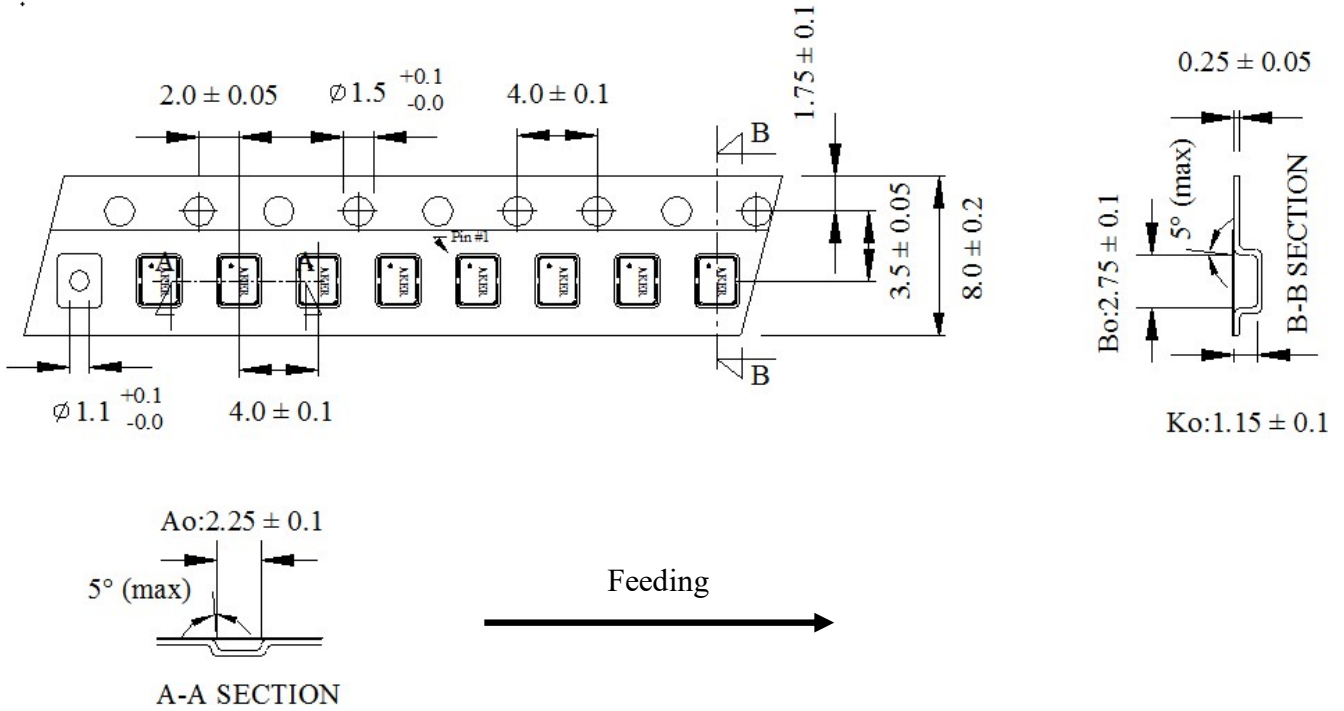

OUTLINE DIMENSION

(Unit : mm)

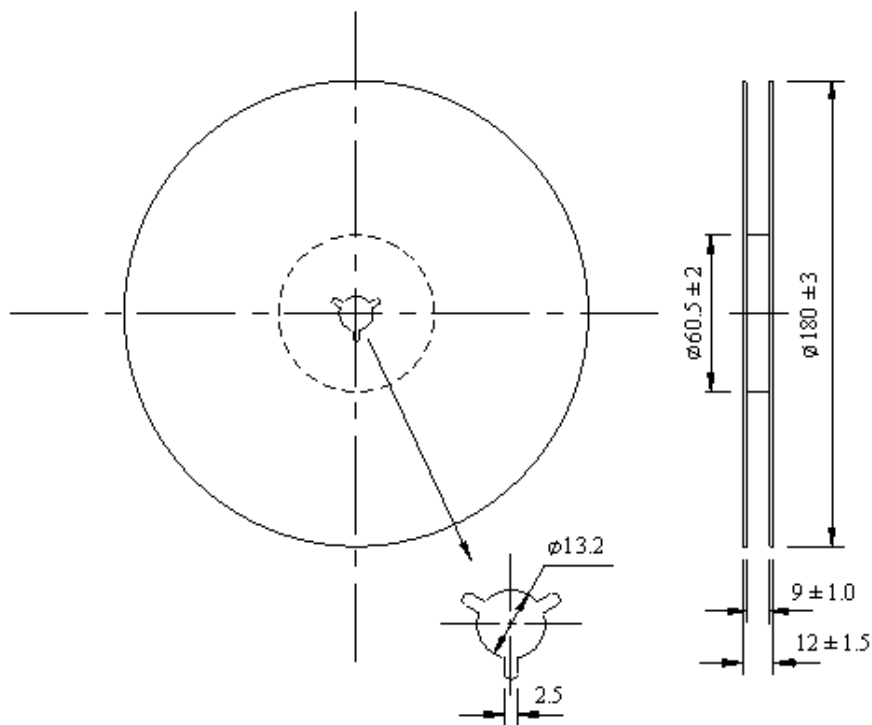

6. COVER TAPE ADHESION STRENGTH :

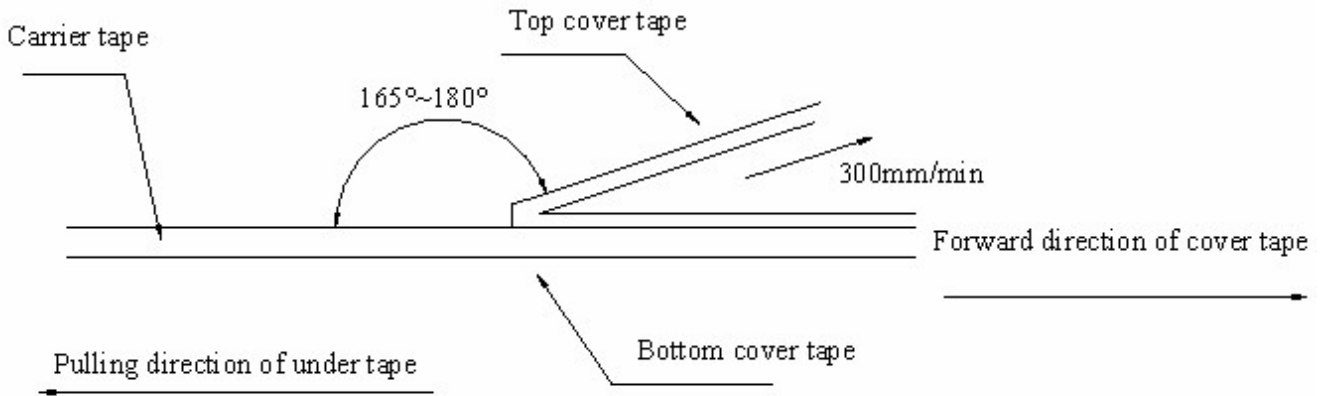

*** In the case, the cover tape is pulled off under the above conditions, the cover tape adhesion strength should be $10.2\text{g} \sim 71.4\text{g}$

Plastic tape: $10.2\text{g} \sim 71.4\text{g}$

(Cover tape adhesion strength)

7. SOLDERING REFLOW PROFILE

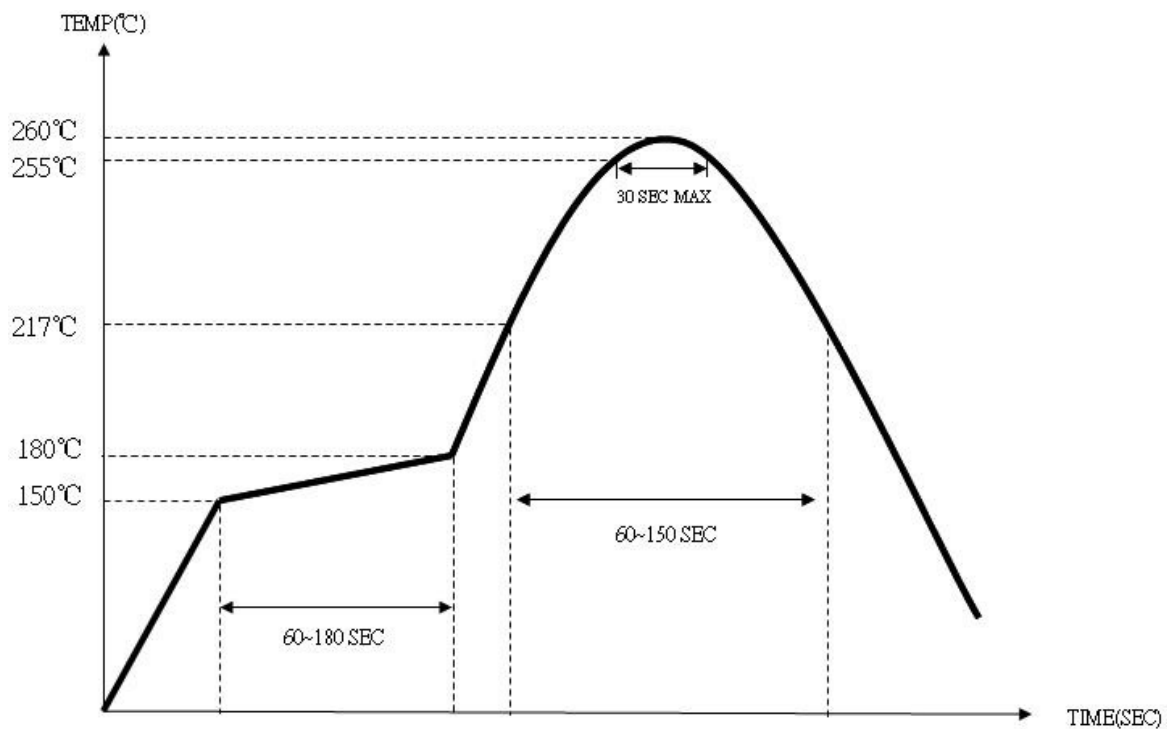

8. PACKING :

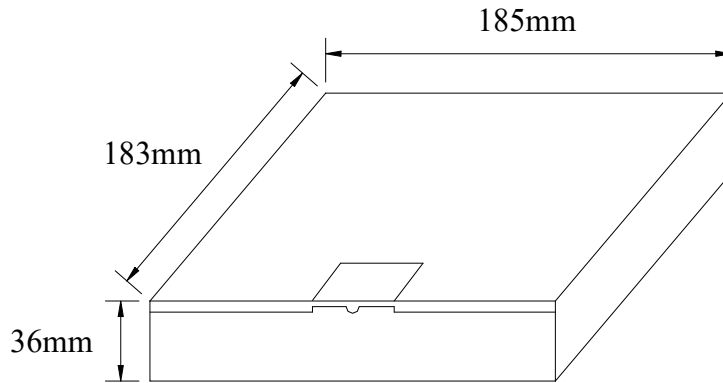

PIZZA BOX = 3000 PCS / REEL(MAX)

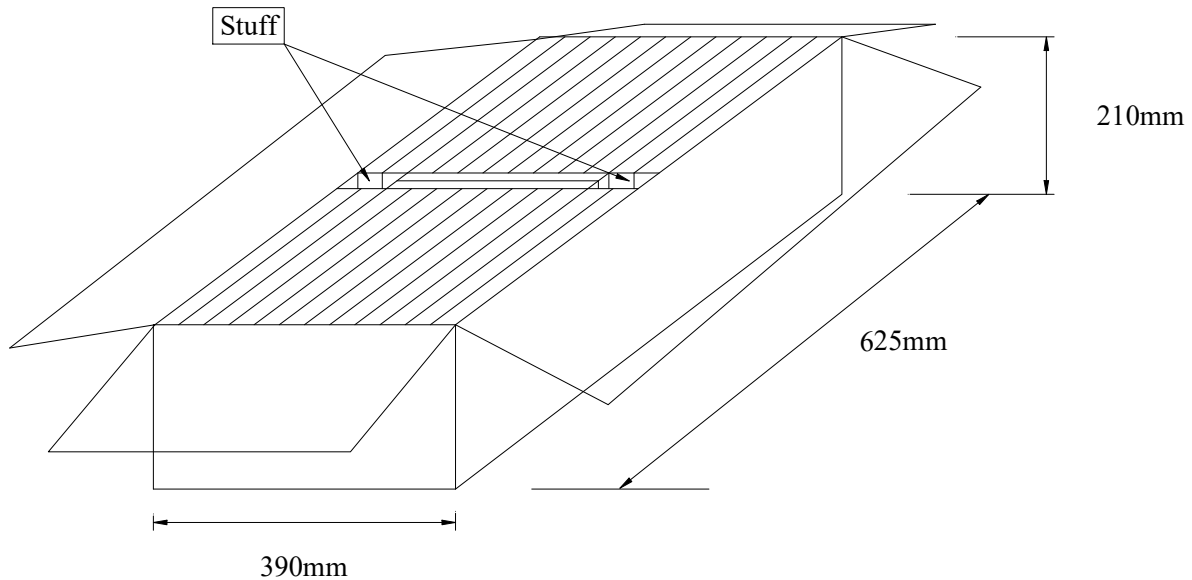

SMD product packs 32 BOX = The outside box packs (3000 PCS * 32 BOX = 96000 PCS)(MAX)



Aker Approved P/N : TXOF-038400-2-D4-01	
APPROVED	: Tin SHEET : 8 of 8
PREPARED	: Hitome REV. : 1
Confidential	

9. MECHANICAL PERFORMANCE

TEST ITEMS	TEST METHODS AND TEST CONDITION	PERFORMANCE
9.1 Temperature Cycling	-40±3°C/30min maximum~+85±3°C/30min maximum , 1000cycles	$\Delta F \leq \pm 2 \text{ppm}$
9.2 Operational Life	85°C±3°C , 1000hrs±12hrs Rated VDD applied.	$\Delta F \leq \pm 2 \text{ppm}$
9.3 Biased Humidity	85°C±5°C&85%±5%R.H. , 1000±12hrs Rated VDD applied.	$\Delta F \leq \pm 2 \text{ppm}$
9.4 Resistance To Soldering Heat Test	Reflow test 2 times.	$\Delta F \leq \pm 2 \text{ppm}$
9.5 High Temperature Exposure	85°C±3°C , 1000hrs±12hrs	$\Delta F \leq \pm 2 \text{ppm}$
9.6 Vibration Test	Freq.range: 10~2000Hz , Peak to peak amplitude:1.52mm Peak acceleration:5G (49m/s ²) , 3 direction(X, Y,Z) , 20min 12cycles each of 3 orientations.	$\Delta F \leq \pm 2 \text{ppm}$
9.7 Mechanical Shock	100G , 6mS , 3 times for each direction(X, Y, Z) , 3 cycles	$\Delta F \leq \pm 2 \text{ppm}$
9.8 Physical Dimension	Verify physical dimensions to the applicable device detail specification.	
9.9 Solderability	260°C , Coated > 95%	
9.10 Board Flex	PCB=100*40(mm) , Bending=2 mm (min) , Duration=60+5/-0 sec	$\Delta F \leq \pm 2 \text{ppm}$
9.11 External Visual	Inspect device construction and marking.	
9.12 Terminal Strength	A force of 17.7N for 60 seconds.	$\Delta F \leq \pm 2 \text{ppm}$